

THIS DRAWING IS UNPUBLISHED. RELEASED FOR PUBLICATION
 © COPYRIGHT 19 BY AMP INCORPORATED. ALL RIGHTS RESERVED.

LOC	DIST	REVISIONS			
P	LTR	DESCRIPTION	DATE	DWN	APVD
CM	53	F	REV AND REDRAWN PER EC 0L30-0001-96	9-12-96	JH RS

1. WIRE RANGE: 12-10 (3-6mm²) AWG
 INSULATION RANGE: .185 MAX.

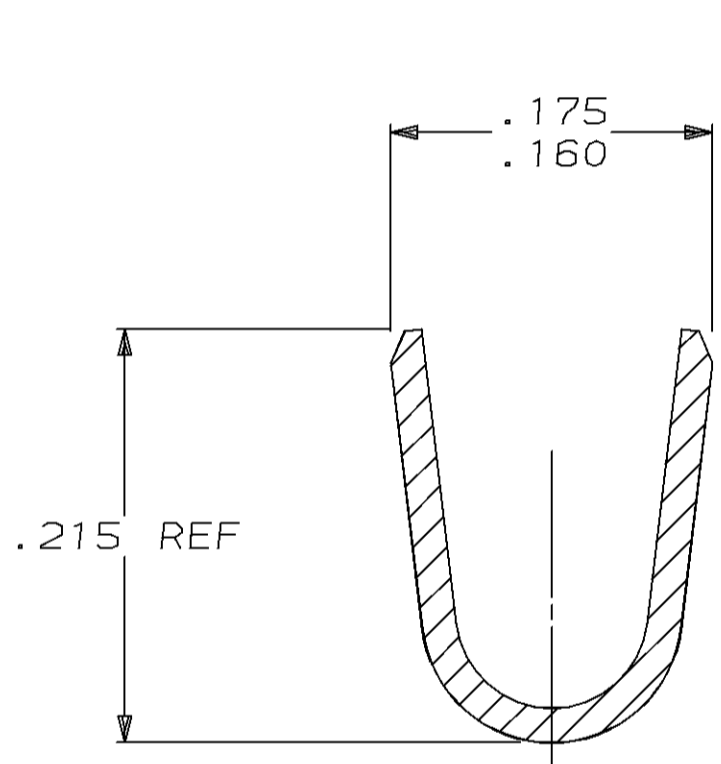
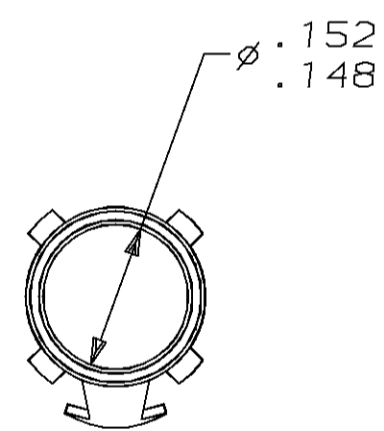
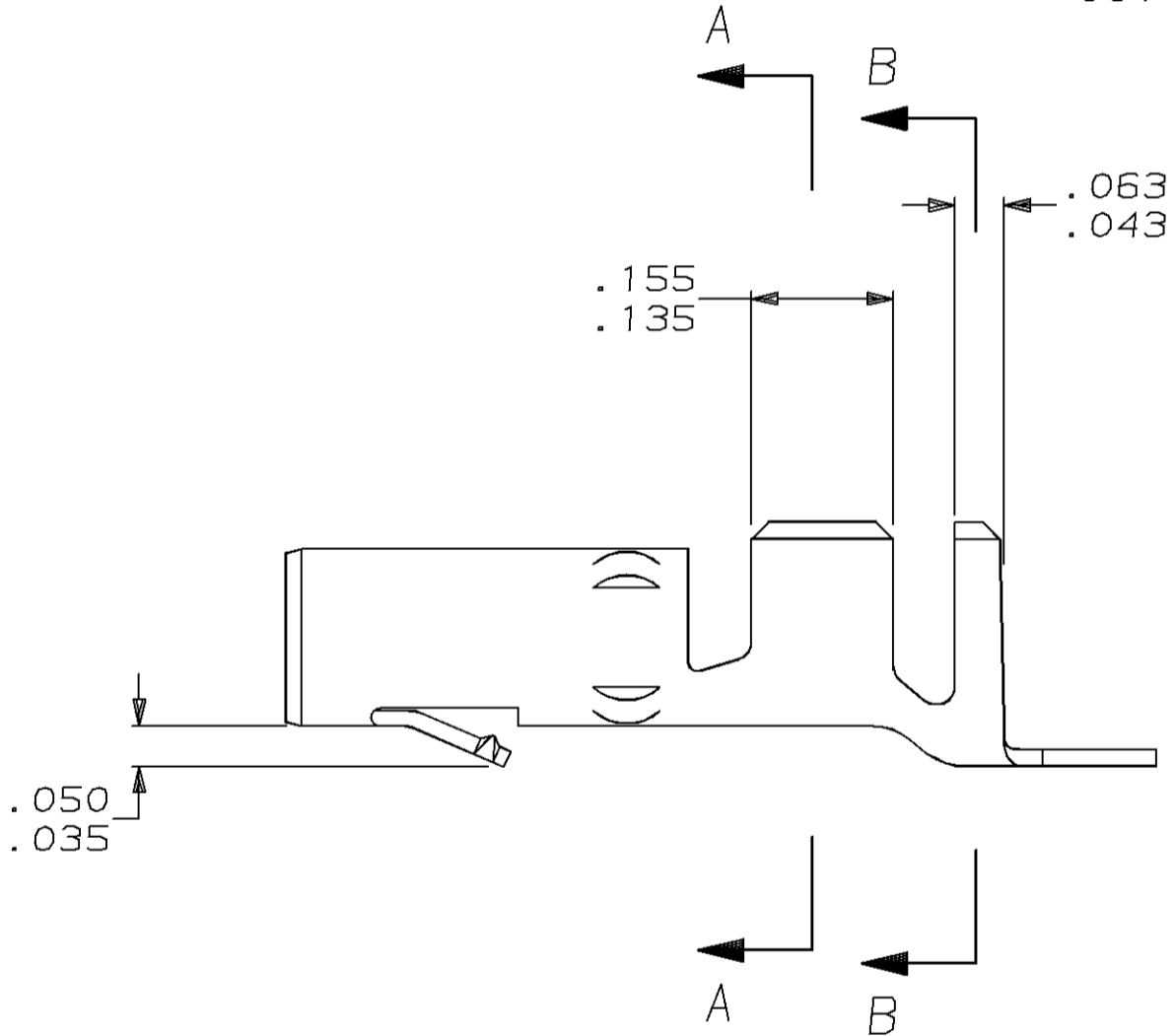
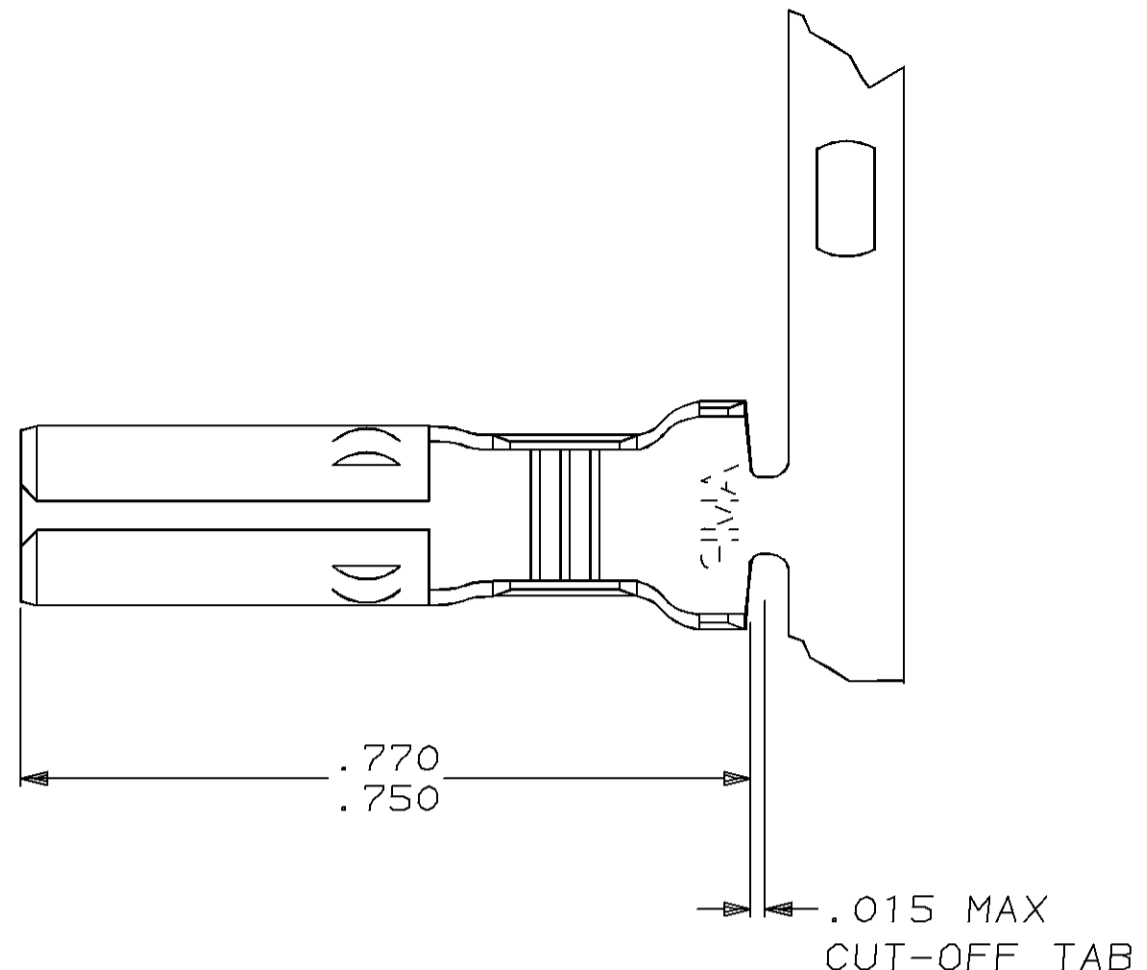

SECTION A-A
SCALE 10:1

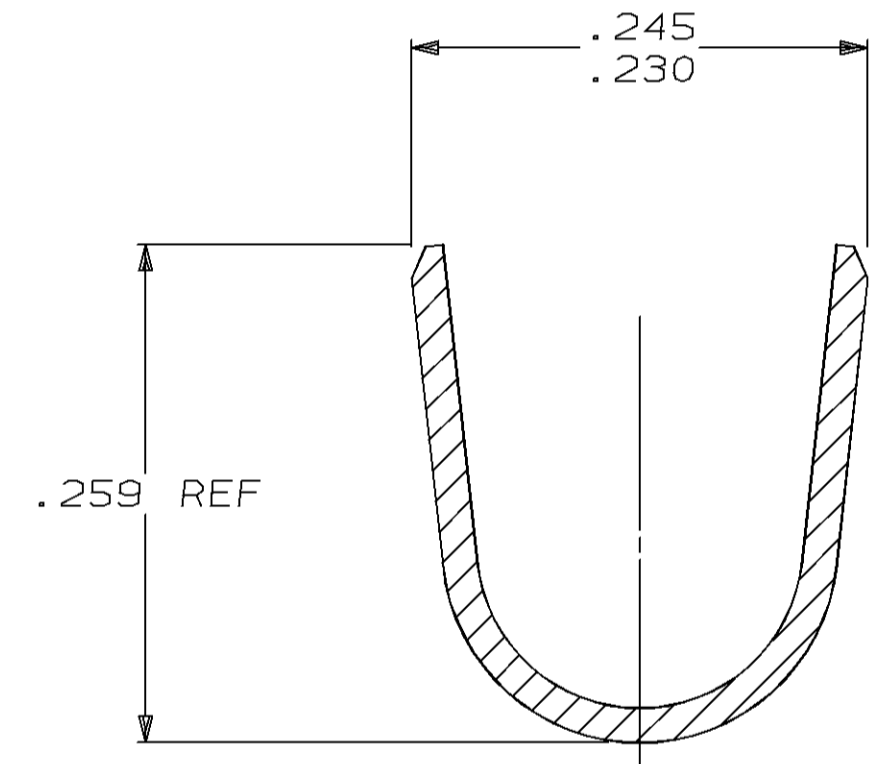

SECTION B-B
SCALE 10:1

TIN	.018 BRASS	61233-1
FINISH	MATERIAL	PART NO

IN	MM	IN	MM	IN	MM	IN	MM
.050	1.27	.156	3.96	.245	6.22		
.043	1.09	.155	3.94	.230	5.84		
.035	0.89	.152	3.86	.215	5.46		
.018	0.46	.148	3.76	.185	4.70	.770	19.56
.015	0.38	.135	3.43	.175	4.45	.750	19.05
.005	0.13	.063	1.60	.160	4.06	.259	6.58

CONVERSION TABLE

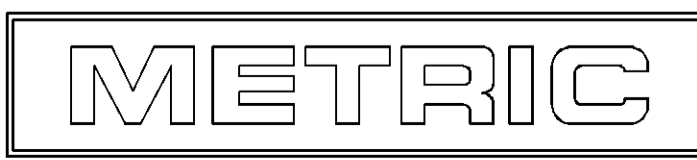

THIS DRAWING IS A CONTROLLED DOCUMENT.

DIMENSIONS: INCHES	TOLERANCES UNLESS OTHERWISE SPECIFIED:	DWN J. HUFFMAN 9-12-96	AMP Incorporated Harrisburg, PA 17105-3608
	0 PLC ±	CHK R. SWING 9-12-96	
	1 PLC ±	APVD C. MARTIN 9-12-96	
	2 PLC ±	NAME	
MATERIAL SEE TABLE	FINISH SEE TABLE	PRODUCT SPEC -	SOCKET, .156 MATE-N-LOK™
		APPLICATION SPEC -	SIZE A2
		WEIGHT -	CAGE CODE 00779
		CUSTOMER DRAWING	DRAWING NO C-61233
			SCALE 5:1
			SHEET 1 OF 1
			REV F

61233